

- 1
- 2
- 3
- 4
- 5
- 6
- 7
- 8
- 9
- 10
- 11
- 12
- 13
- 14
- 15

MATERIAL

Glass-fibre reinforced polyamide based (PA) technopolymer, black colour, matte finish.

PACKING RING

NBR synthetic rubber.

STANDARD EXECUTIONS

- **TCD.**: without side hole.
- **TCDF.**: with side breather hole.

MAXIMUM CONTINUOUS WORKING TEMPERATURE

100°C.

GRAPHIC SYMBOL "FILL"

According to DIN regulations.

TECHNICAL DATA

The tightening torque indicated in the table guarantees an optimal tightness, keeping the packing ring in the correct position.

ACCESSORIES ON REQUEST

TCD. oil fill plugs are suitable for mounting aluminium plates with graphic symbols type MH. (see page 1146).



ELESA Original design

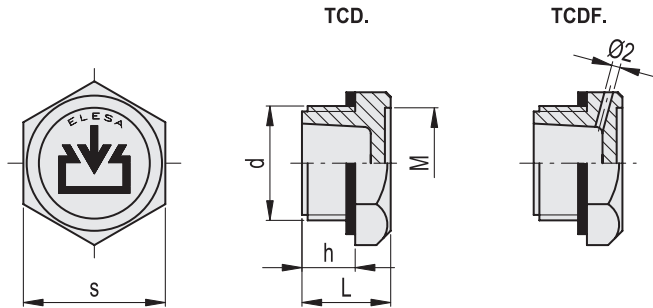

TCD.

TCDF.

Code	Description	Code	Description	d	h	s	L	M	Tightening torque [Nm]	⚖
58551	TCD.10x1.5	58651	TCDF.10x1.5	M10x1.5	9	19	16	15	4+5	4
58553	TCD.12x1.5	58653	TCDF.12x1.5	M12x1.5	9	19	16	15	6+8	4
58555	TCD.14x1.5	58655	TCDF.14x1.5	M14x1.5	9	19	16	15	6+8	5
58557	TCD.16x1.5	58657	TCDF.16x1.5	M16x1.5	9	22	16	17	8+10	7
58559	TCD.18x1.5	58659	TCDF.18x1.5	M18x1.5	11	26	18	20.5	8+10	8
58561	TCD.20x1.5	58661	TCDF.20x1.5	M20x1.5	11	26	18	20.5	8+10	8
58563	TCD.22x1.5	58663	TCDF.22x1.5	M22x1.5	12	32	20	25	10+12	12
58565	TCD.25x1.5	58665	TCDF.25x1.5	M25x1.5	12	32	20	25	10+12	12
58569	TCD.26x1.5	58681	TCDF.26x1.5	M26x1.5	12	32	20	25	10+12	14
58567	TCD.35x1.5	58667	TCDF.35x1.5	M35x1.5	13	38	22	31	15+18	15
58571	TCD.40x1.5	58683	TCDF.40x1.5	M40x1.5	14	46	24	38	15+18	20
58591	TCD.1/8	58669	TCDF.1/8	G 1/8	9	19	16	15	4+6	4
58601	TCD.1/4	58671	TCDF.1/4	G 1/4	9	19	16	15	4+6	4
58611	TCD.3/8	58673	TCDF.3/8	G 3/8	9	22	16	17	8+10	5
58621	TCD.1/2	58675	TCDF.1/2	G 1/2	11	26	18	20.5	8+10	8
58631	TCD.3/4	58677	TCDF.3/4	G 3/4	12	32	20	25	10+12	14
58641	TCD.1	58679	TCDF.1	G 1	13	38	22	31	12+15	18
58643	TCD.1¼	58685	TCDF.1¼	G1 1/4	14	46	24	38	15+18	20
58645	TCD.1½	58687	TCDF.1½	G1 1/2	15	55	26	46	15+18	24

Accessories for hydraulics